



AC ADAPTERS POWER SUPPLY

Catalog

...TECHNOLOGICAL INNOVATIONS
AT THE TOUCH OF YOUR FINGER TIPS



V
IV
VI

EFFICIENCY STANDARDS FOR EXTERNAL POWER SUPPLIES

Efficiency Standards Timeline / The Current Regulatory Environment.

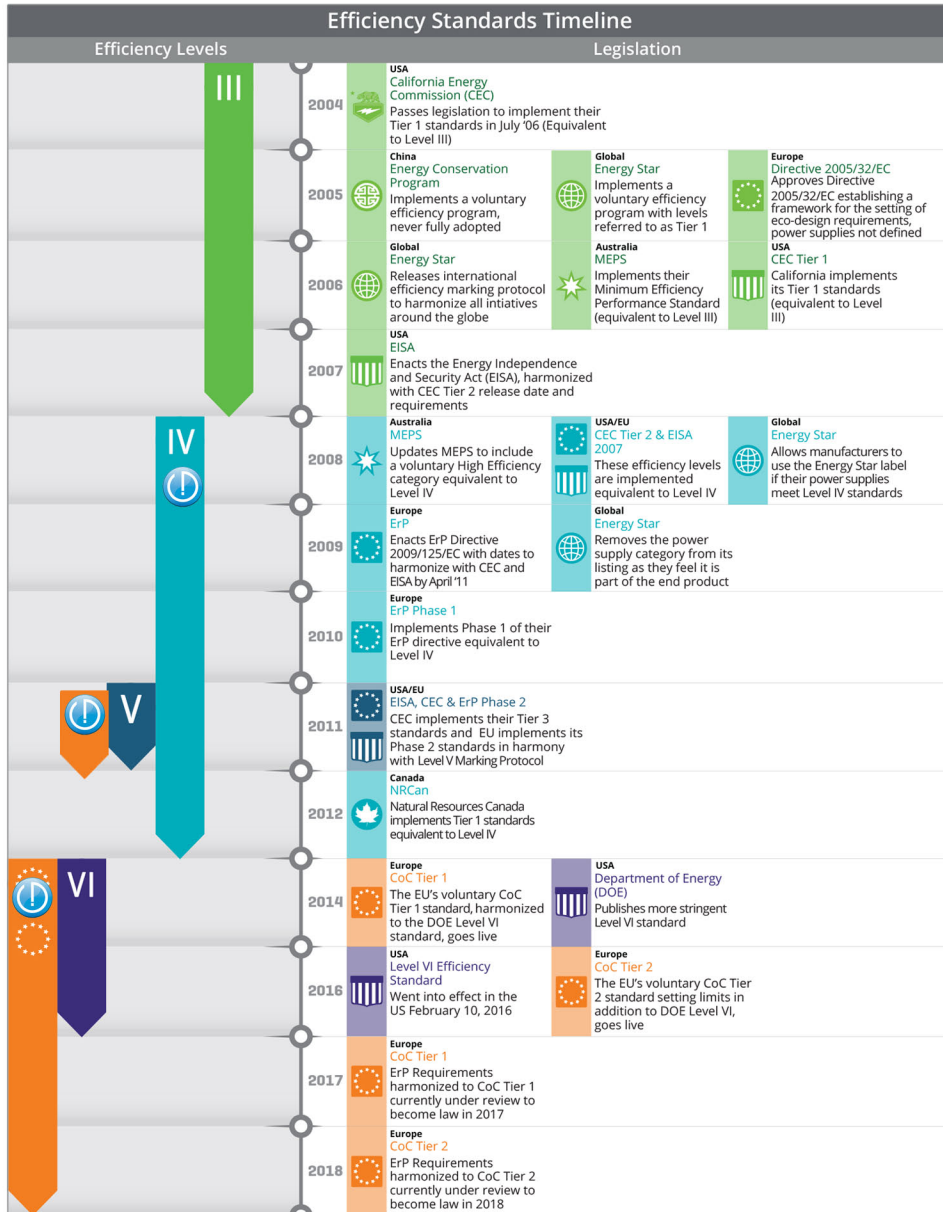

This infographic traces the path from CEC's 2004 regulation up to the latest DoE Level VI standard, which became effective in February 2016, and also shows the EU roadmap for Ecodesign requirements.

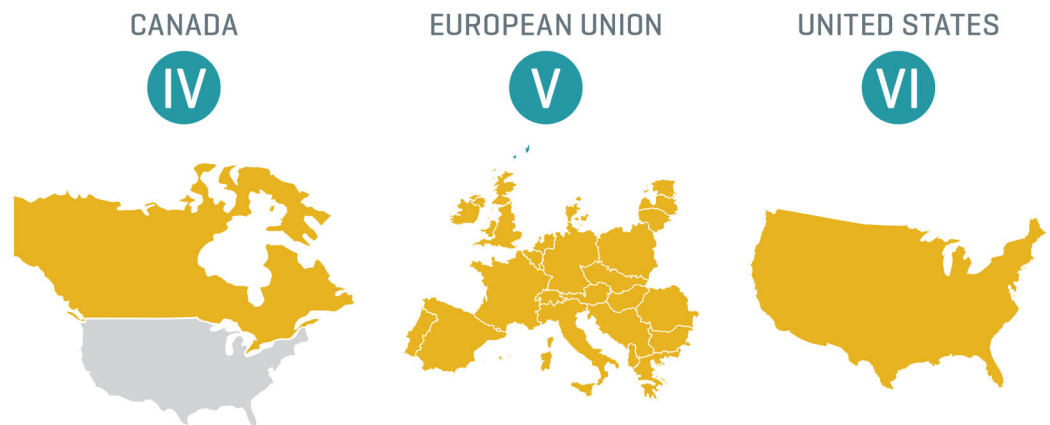

This graphic shows the latest mandatory efficiency standard regulations by region.

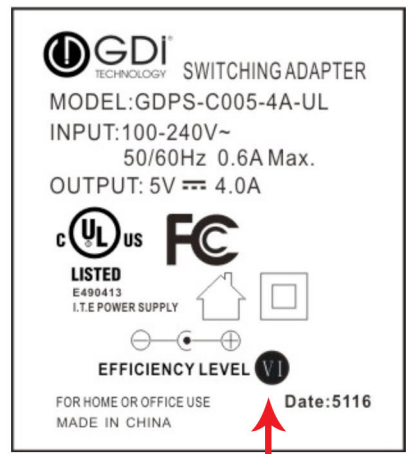

Example of International Efficiency Marking Protocol on a power supply label.



DoE Level VI and CoC Tier 2 compliant power supplies

See more at www.gditechnology.com

EFFICIENCY STANDARDS FOR EXTERNAL POWER SUPPLIES

Efficiency Standards Timeline / The Current Regulatory Environment.

BRICK TYPE



WALL TYPE



PLUG TYPES

type A	type B	type C	type D	type E	type F	type G	type H	type I	type J	type K	type L
USA CUBA MEXICO CANADA JAPAN	USA CUBA MEXICO CANADA JAPAN	EUROPE SOUTH AMERICA ASIA	UNITED KINGDOM INDIA	FRANCE BELGIUM POLAND SLOVAKIA CZECH REPUBLIC	EUROPE RUSSIA GERMANY	UNITED KINGDOM IRELAND MALTA MALAYSIA SINGAPORE	ISRAEL	ARGENTINA AUSTRALIA CHINA NEW ZEALAND	SWITZERLAND LIECHTENSTEIN RWANDA	DENMARK GREENLAND	ITALY CHILE



EFFICIENCY STANDARDS FOR EXTERNAL POWER SUPPLIES

Efficiency Standars Timeline / The Current Regulatory Environment.

UNIVERSAL ADAPTERS



Universal Muti Voltage AC/DC Adapter with Selectable Adapter Plugs

AC Adapters with Selectable Plugs

DC JACK TYPE



Adapters available in any DC jack size

Pin size customized

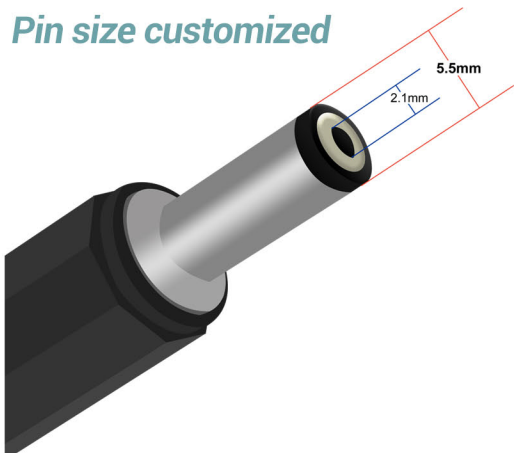

COMPILANT WITH UL STANDARDS

*Available in 5V, 6V, 7.5V, 10V, 11V, 15V, 24V series.

UL, GS, CE, C-TICK, PSE, FCC approved.
RoHS, REACH, PAHs compliant & Energy efficient.

We manufacture replacement AC Adaptors to your specifications for use in US, Canada, Europe, UK, Australia, Japan.



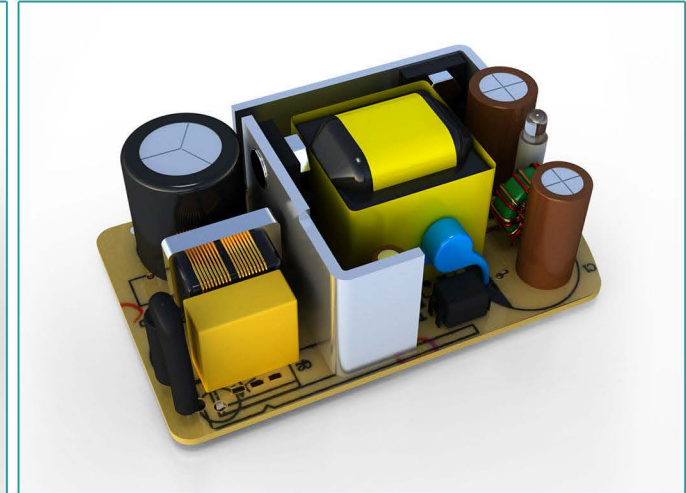
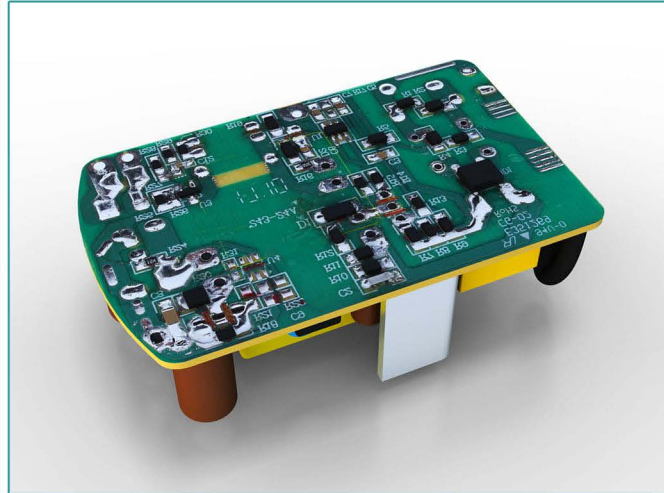

2021 Slick Design Model with LED

- **Sturdy Multy-Layer circuit design.**
- **Smart voltage irregularity controller** (handles voltage spikes from 75-240V)
- **Energy efficiency rated.**
- **2021 Level 6 with SMT Technology.**
- **Supperior component built with dual.**
- **L-Shape heatsink for proper heat decipitation.**
- **2 years warranty.**
- **Compatible for all mayor brands**

(Arris, Cisco, Motorola, SMC, Ubee, Pace, Technicolor, Hitron, etc.)





... technological innovations at the touch of your finger tips

-  12400 SW 134 CT. Suite 14 Miami, FL 33186
-  1(800) 582-5116 | (305) 969-2047
-  305.969.8853
-  sales@gditechnology.com
-  WWW.GDITECHNOLOGY.COM



*Some cases are available for physical sample only upon special request. These renderings are for reference only. It is not to scale, and design features may vary upon engineering review. This is proprietary information of GDI Technology Inc.